

adaptiv
DIC

myWall.

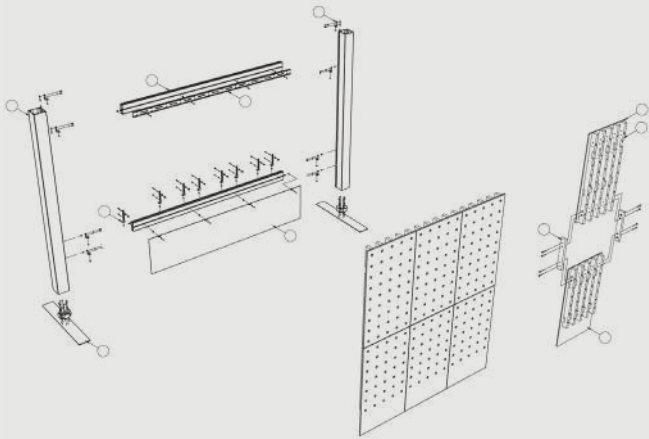

Form and Function, Every Time.

myWall.

MODULAR OFFICE SYSTEM

Most versatile office system on the market in the United States.

AdaptivDC is the proud provider of the (Thinkterior) myWall Inline Display System, a breakthrough in display hardware, and provides design, fabrication and installation to business clients across the United States.

The myWall Inline Display System is an out-of-the-box office solution that allows you to customize your work space according to the needs of the day. It's load bearing (pile on the product!); easy to assemble/disassemble; and its' high-quality design and construction give you the ability to organize your office to the best effect again and again. The wide range of available accessories allow additions and modifications to your work space over time, and are very competitively priced.

You can use myWall on existing walls, especially useful in open, shared offices. To do so, you don't need the myWall free standing structure, just a myWall panel and a connector clip. You can also use both sides of any wall or cubicle, creating outlying work spaces on the other side of the divider.

You won't have to significantly re-route building infrastructure, including electricity. You can still use your standard power plugs and we recommend hanging pendant lights as both functional light and decorative elements. One add-on option relevant to work settings: add foam soundproofing to panels to lower noise levels. You can use myWall in the office AND take it with you on the road. Quickly disassemble it, use it at the show, then set it right back up in the office. The best thing? Once you have the system, you can make it fit your needs over and over again, as personnel and your business evolve.

Form and Function, Every Time.



Load bearing system

myWall.

Overall system is customizable into many other structure shapes and configurations.

Key Point!

myWall's patent pending locking pin system allows users to use both the front or back of the wall panels for product display, storage, and increased marketing surface.

Thanks to the locking pins, myWall becomes an ultra safe display surface capable of handling all the equipment and product you want to throw at it.

ABOUT MYWALL

The myWall Inline Office System is the perfect piece of mobile infrastructure for companies looking to make their offices stand out. Rooted in design cues derived from both Scandinavian and Japanese design, the high-quality myWall system is designed to provide companies with a mobile, modular and customizable work space system ready to be used time and again. It's extremely sturdy and load bearing--perfect for display no matter the weight. Finally, The freedom of customization makes each office unique for every employee.

KEY FEATURES

- High-end design
- Easily customizable, wide variety of accessories
- Sturdily crafted
- Increase ROI, use again and again
- Easy to assemble, minimal tools
- Don't be generic, stand out
- Cost efficient compared to fully customized solutions
- Complete customization with modular plug-and-play shelving
- Durable, environmentally friendly hardwood panels (recycled aluminum & renewable rubber wood)
- Modular savings: start simple and build up on a budget
- Structural support for products, displays, TV's, etc.
- Load bearing system for heavy object display



* Custom items available upon request

myWall.

SAMPLE USES



10X10 Office Cube



shelving



10X10 Office Cube



general storage



Lighting management (pendant light brackets)



organization

wire management

myWall.

OFFICE STRUCTURES

Overall system is customizable into many other structure shapes and configurations.

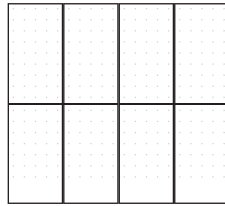

4 Panel

10x10 space
Back wall

Dims:
2743mm W (9')
2438mm H (8')

Panels:
4 mywall

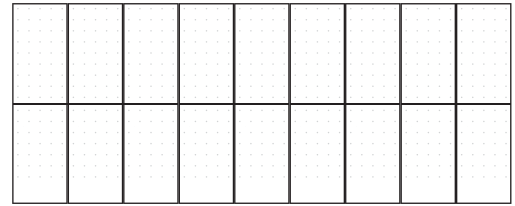

9 panel

10x20 space
Back wall

Dims:
5791mm W (19')
2438mm H (8')

Panels:
9 mywall

Island cube provides storage on interior surfaces or for use as additional office area.

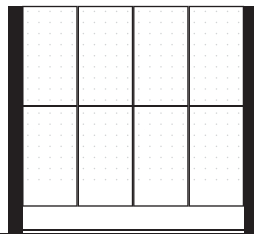

20x20 space
Island System

Dims:
2743mm W (9')
2438mm H (8')

Panels:
16 mywall

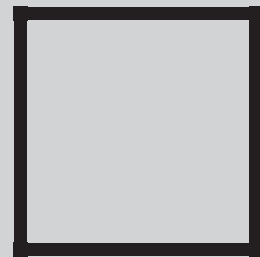

10x10 CUBE

myWall.

HOW THE SYSTEM WORKS

myWall locking pin system

This patent pending locking pin system allows users to use both the front or the back of the wall panels for product display, storage, and marketing surface.

Pins work on both the front and back of the wall system, providing extra storage behind your wall when in cube form.

With the use of locking pins, the structure becomes a safe display surface for multiple objects or office management items.

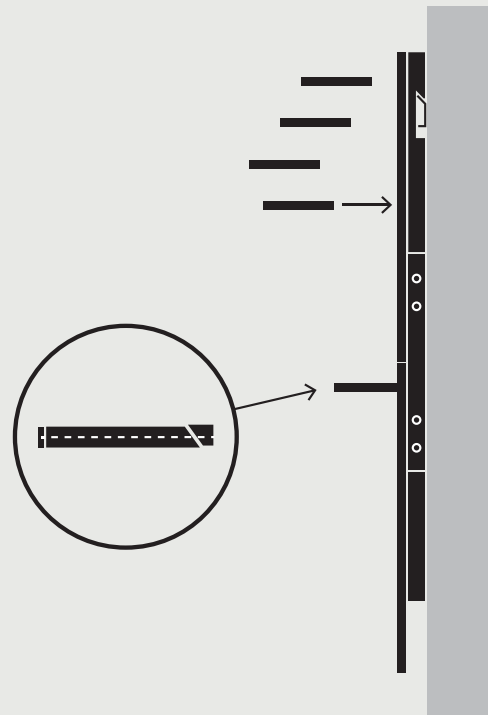
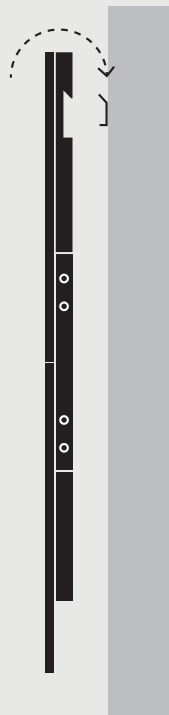
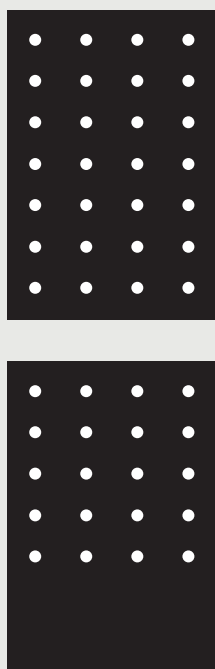

myWall.

PRODUCT STRUCTURE DETAILS (cube system)

Product Items List

- 1 Vertical Tower Support
- 2 Support Base Plate
- 3 Horizontal Support Beam
- 4 French Cleat Bracket
- 5 Lower Wall Locking Plate
- 6 Skirt
- 7 Horizontal Support Bracket
- 8 myWall upper panel
- 9 myWall lower panel
- 10 myWall vertical support
- 11 myWall upper/lower connector

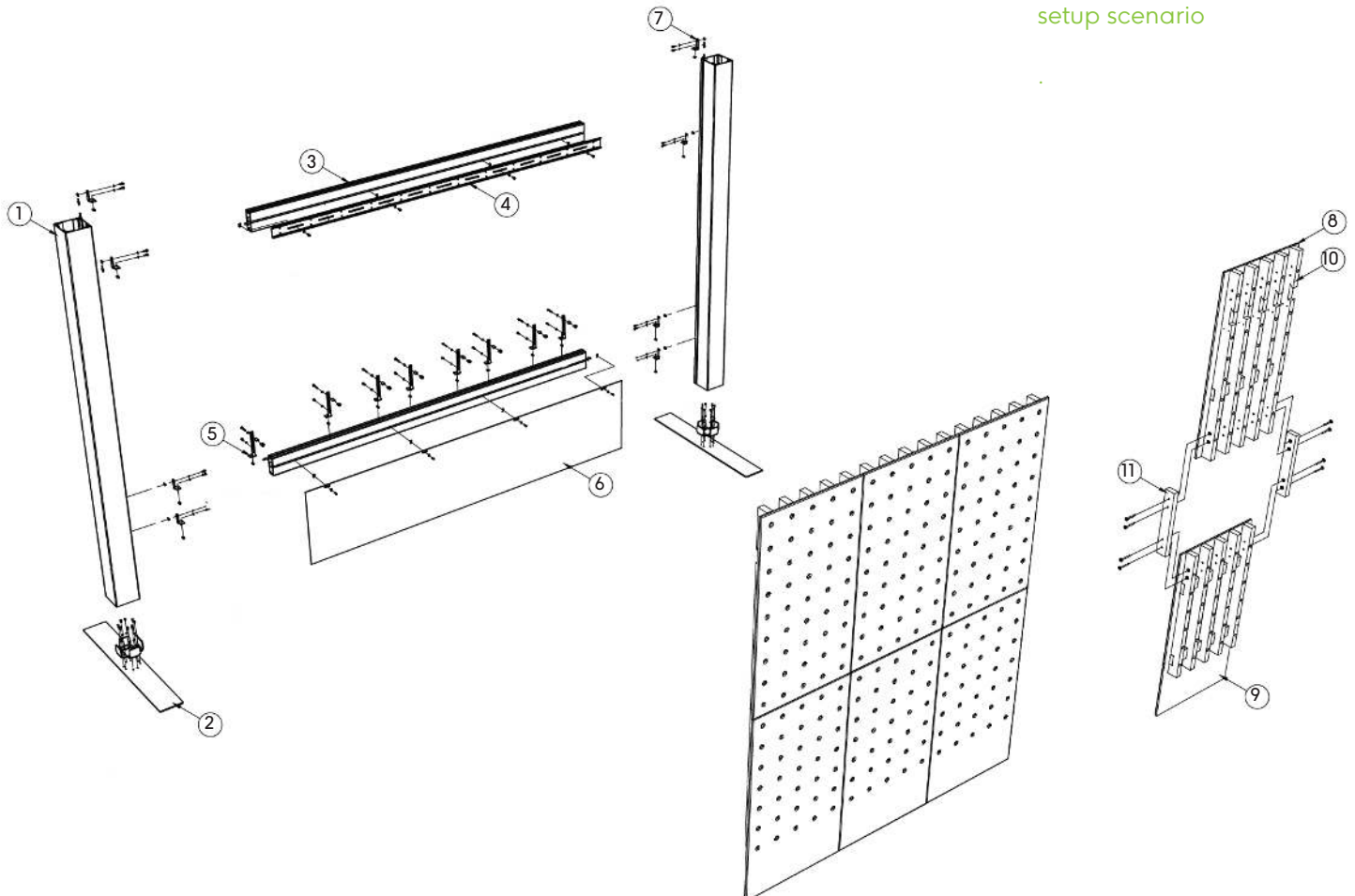

System shown in cube wall setup scenario

PRODUCT STRUCTURE DETAILS (wall installation system)

Product Items List

- 1 myWall upper panel
- 2 myWall lower panel
- 3 French Cleat Bracket
- 4 myWall vertical support
- 5 myWall upper/lower connector

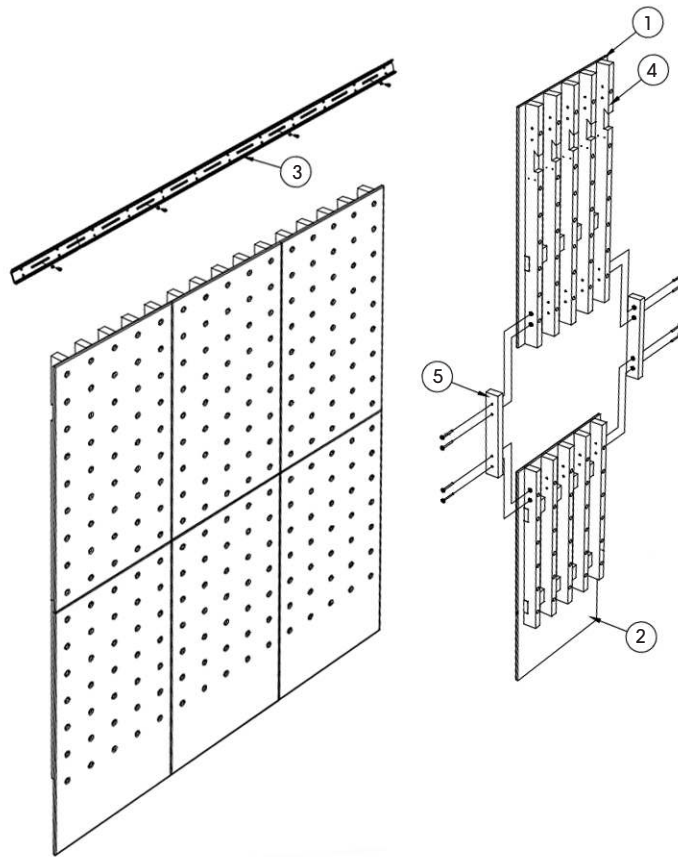

myWall panels attach as an upper and lower section, that then hang onto upper horizontal french cleat mounted to wall.

ITEMS

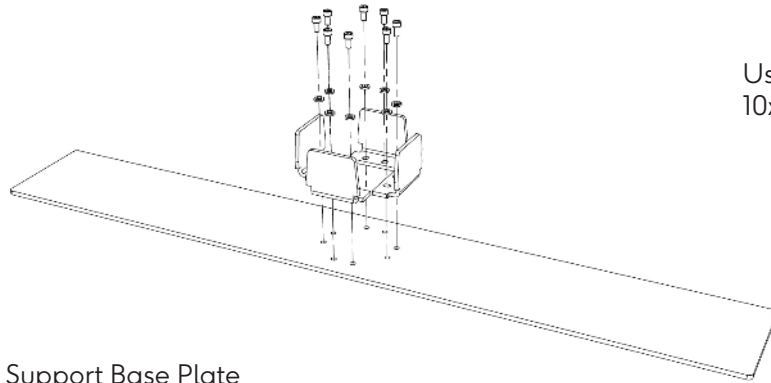

Used as base for 10x10 and 10x20 inline wall units

2

Support Base Plate

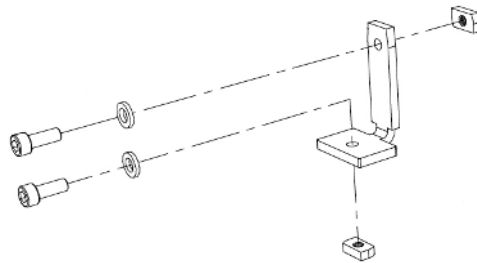

Used for locking horizontal supports onto vertical tower supports.

7

Horizontal Support Bracket

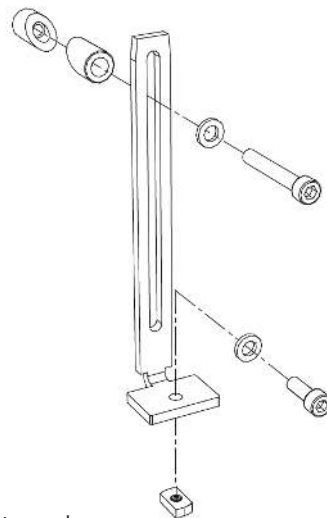

Used for locking lower section of myWall panels into the lower horizontal support beam

5

Lower wall locking plate

ITEMS

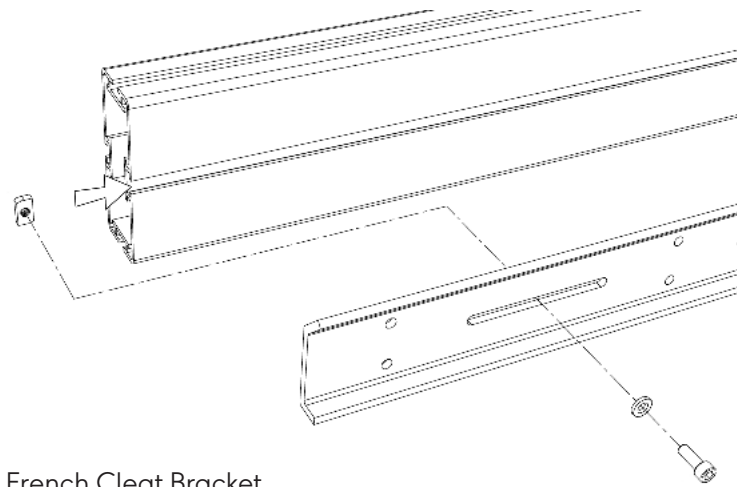

Cleat is used to hold myWall panels and is mounted directly to upper horizontal support beam.

4

French Cleat Bracket

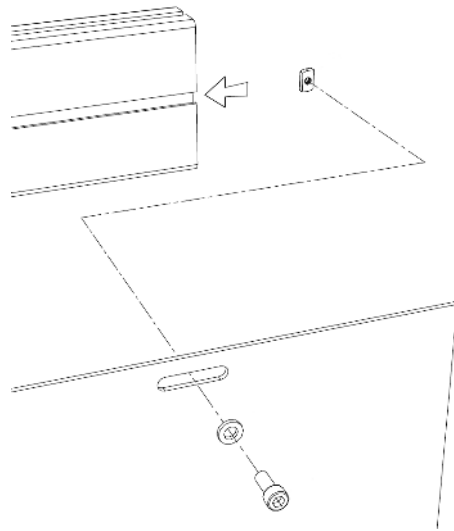

Lower skirt mounts directly to lower horizontal support beam.

6

Skirt

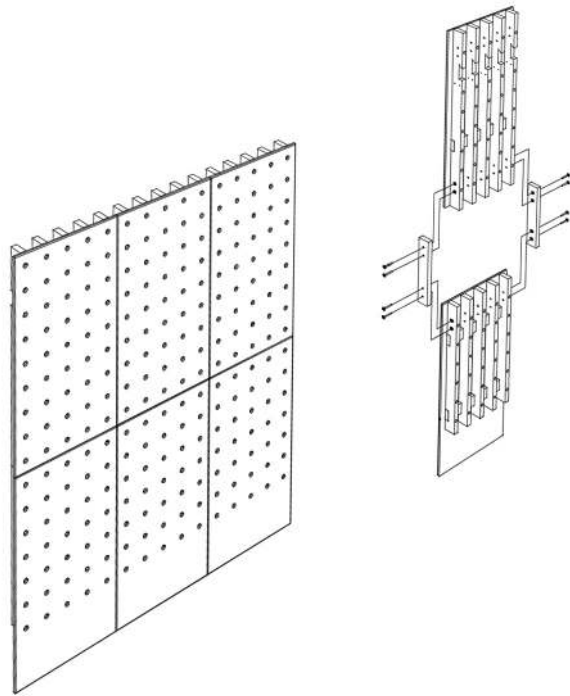

myWall panels attach as an upper and lower section, that then hang onto upper horizontal support beam with the use of the french cleat.

8/9

myWall Panels (upper / lower sections)

RENEWABLE RESOURCES

The myWall system uses rubber wood, a renewable and sustainable byproduct of the latex industry.

Reduce: We work with our manufacturing partners to ensure we are leaving as small a carbon footprint as possible.

Re-use: Our products are durable and designed to last, cutting down the need to discard our products and purchase new ones.

Recycle: Our products and components use recyclable materials.



myWall is a registered trademark and patent pending design of Thinkterior Studio Pte Ltd, Singapore.

All Rights Reserved.
©2017



AdaptivDC
42395 Ryan Road
Suite 112 / PMB 212
Ashburn, VA 20148

703. 929. 3229
hello@adaptivdc.com
adaptivdc.com